

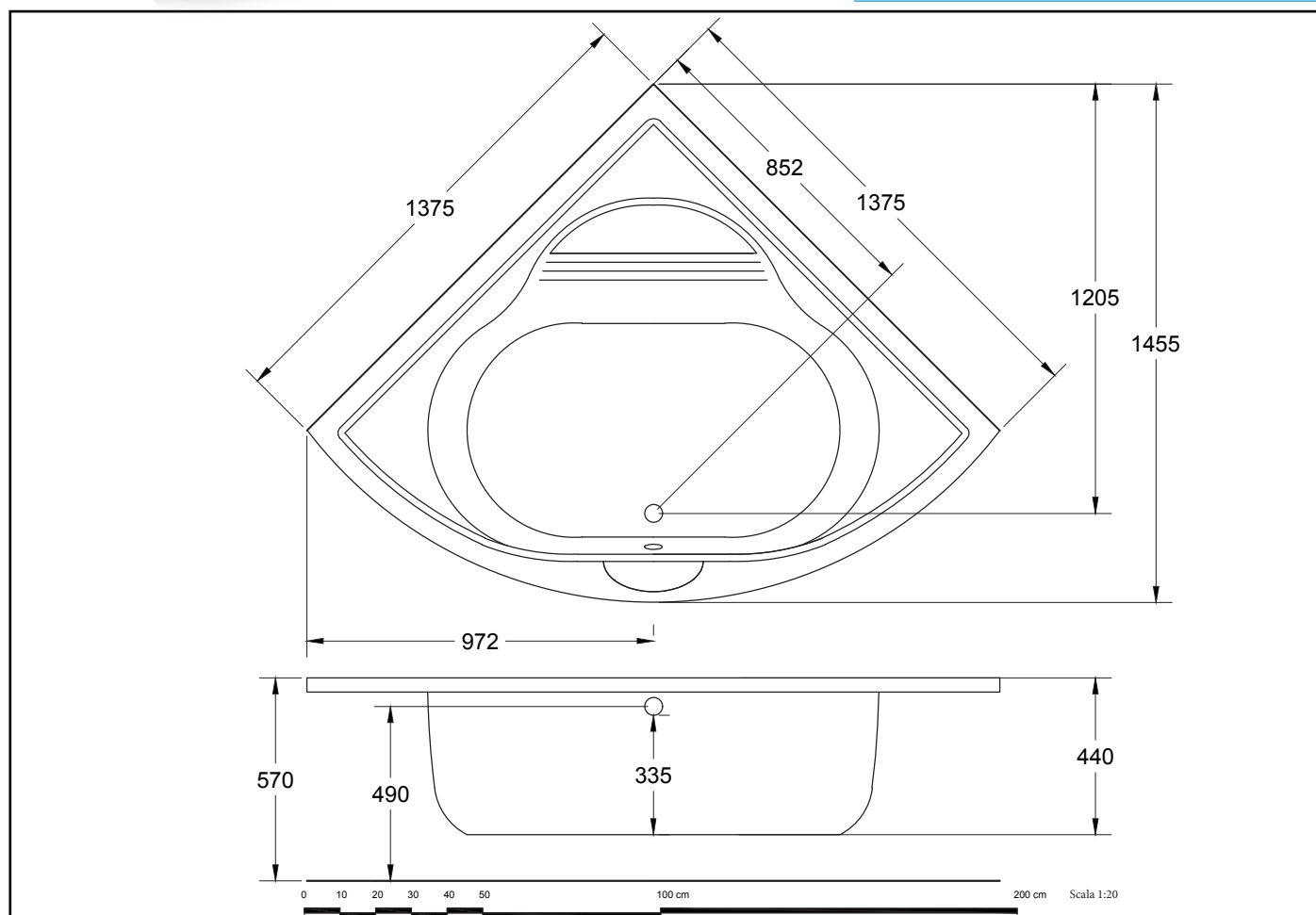

**CARATTERISTICHE ELETTRICHE**  
**ELECTRICAL FEATURES**

<b>Voltaggio</b> <i>Voltage</i>	220 Volt
<b>Tension</b> <i>Tension</i>	50 Hz
<b>Potenza motore</b> <b>IDROMASSAGGIO</b> <i>WHIRPOOL motor power</i>	0,8 hp (Standard) 1,00 hp (4 mini-jet)
<b>Potenza assorbita</b> <b>IDROMASSAGGIO</b> <i>WHIRPOOL absorbed power</i>	810 Watt (Standard) 930 Watt (4 mini-jet)
<b>Potenza motore</b> <b>AIRPOL</b> <i>AIRPOL motor power</i>	0,9 hp
<b>Potenza assorbita</b> <b>AIRPOOL</b> <i>AIRPOOL absorbed power</i>	700 Watt
<b>Stabilizzazione temperatura</b> <i>Temperature stabilize</i>	1300 Watt

**Neo**

<b>Jets Idromassagio</b> <i>Whirlpool Jets</i>	<b>Jets airpool</b>	<b>Contenuto Acqua<sup>(1)</sup></b> <i>Water Content <sup>(1)</sup></i> <b>lt</b>	<b>Peso di spedizione</b> <i>Delivery Weight</i> <b>kg</b>	<b>Volume di spedizione</b> <i>Delivery Volume</i> <b>m<sup>3</sup></b>
6	12	200 l	50	1,23

## Installazione idraulica - Installazione elettrica

Hydraulic Installation - Electrical Installation

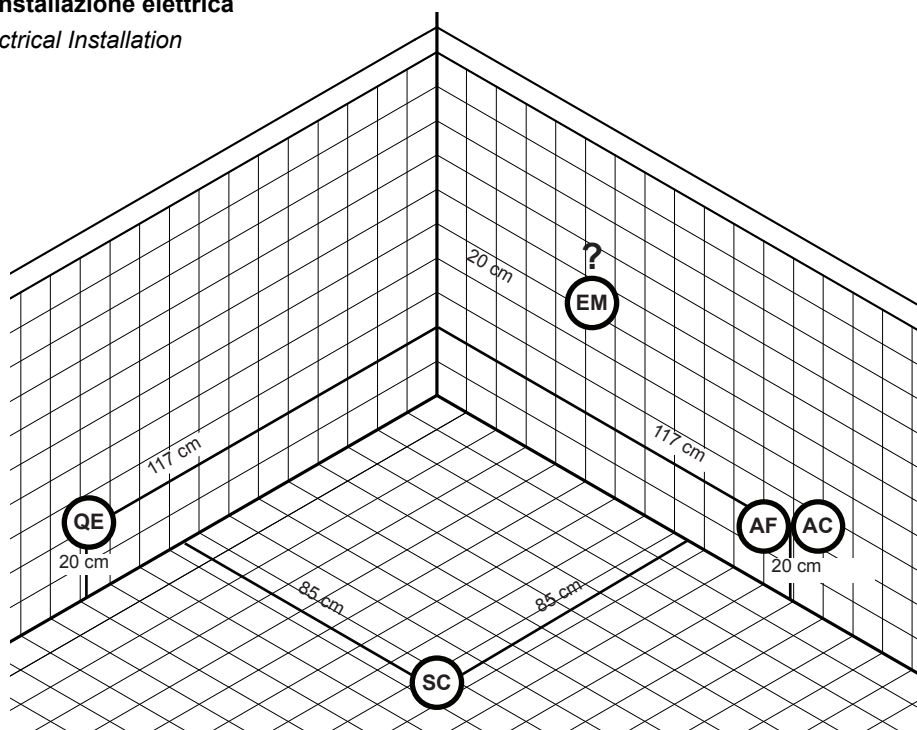

**A monte dell'impianto idraulico si consiglia di installare dei rubinetti filtro.**  
L'Azienda declina problemi derivanti dalla mancata installazione dei suddetti



Allaccio acqua calda nel caso di vasca provvista di rubinetteria



Hot water connection should the bathtub be fitted with taps

Allaccio acqua fredda nel caso di vasca provvista di rubinetteria



Cold water connection should the bathtub be fitted with taps

Scarico a terra consigliato



Recommended grounded drain

Allaccio alimentazione elettrica sezione minima del cavo 3 x 2,5 mmq lunghezza ml 2 circa  
Predisporre l'allaccio elettrico QE solo quando necessario.



Electrical connection with minimum cable section of 3 x 2,5 mmq,

Allaccio rubinetteria muro



Connections for wall mounted taps